

# VISCOFLUX mobile Drum Emptying System



**New!**



# VISCOFLUX mobile

The stand-alone solution for transferring high-viscosity fluids

VISCOFLUX mobile is a mobile and thus very flexible variant of the tried and tested VISCOFLUX drum emptying system. VISCOFLUX mobile is ideal for the gentle conveyance of high-viscosity, paste-like and non-free flowing materials, even from conical drums with aseptic bags. Industrial and Pharma Food Cosmetic versions are available – each for various drum diameters.

## Function description

VISCOFLUX mobile is a stand-alone system with a mobile lifting device and a pump unit composed of motor, pump and follower plate which is individually designed for each application. Steerable rear wheels make it easy to move the system to the drum.

During transfer of the material, the pump unit is lowered by means of a rechargeable battery drive until the follower plate touches the material. Then, the integrated override clutch automatically decouples the pump system from the lifting sledge and the sledge is lowered further independent of the pump system. The self-priming eccentric worm-drive pump creates a vacuum below the follower plate which pulls the follower plate down. This guarantees especially gentle transport of the medium. The flexible sealing lip adjusts even to beads and tapered constrictions, leaving almost no material at the drum wall. In this way, VISCOFLUX mobile achieves residual quantities of less than 1% in the drum and less than 2% if transferred out of aseptic bags. Moreover, the sealing lip hermetically seals the medium and ensures process reliability even if the transferring process is interrupted. After transfer, compressed air lifts the follower plate off the drum bottom and the lifting sledge moves the pump unit out of the drum. When emptying drums with aseptic bags, the inliner is automatically pushed close to the drum wall, at first by the medium and later, when the follower plate is moved out, by the compressed air.

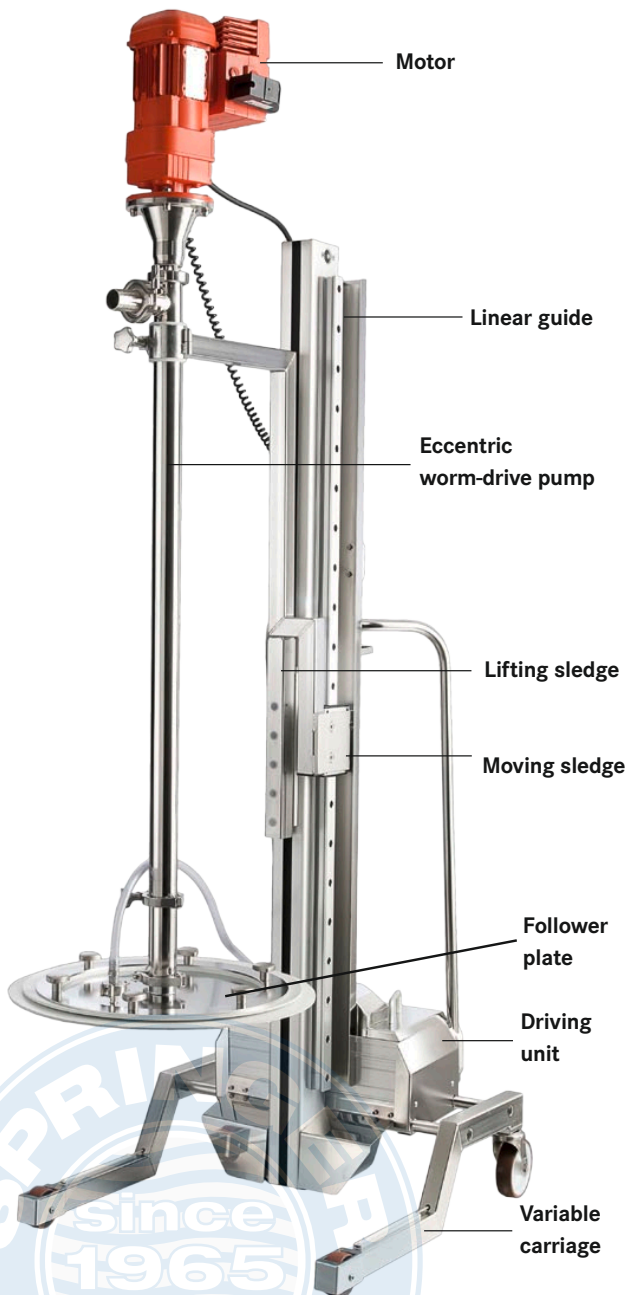

VISCOFLUX mobile, Pharma Food Cosmetic version



VISCOFLUX mobile (Pharma Food Cosmetic), version with double lip for conical drums.

### Product characteristics

- ▶ Stand-alone, mobile system due to integrated mobile lifting device (lifting device can be operated without mains voltage due to rechargeable battery)
- ▶ Designed for various drum diameters
- ▶ Version for conical drums with aseptic bags also available  
Can be adjusted to wider drum diameters on request
- ▶ Emptying with residual quantities of less than 1% (less than 2% in case of aseptic bags)
- ▶ Pump and follower plate can be dismantled quickly and completely
- ▶ The vacuum-operated system ensures low-turbulence, gentle transfer even of non-free flowing materials
- ▶ Overall system has few dead spots
- ▶ Compact design, low space requirement
- ▶ Pump unit consisting of pump, motor and follower plate can be individually configured for to the medium
- ▶ Follower plate can be exchanged

### Pharma Food Cosmetic version

- ▶ Follower plate with double sealing lip for conical drums
- ▶ Also suitable for drums with aseptic bags
- ▶ Stainless steel protective covers
- ▶ Conductive stainless steel castors

### Examples of media

- ▶ Non-free flowing media
- ▶ Media which outgas or react with oxygen
- ▶ Greases up to grease class 3
- ▶ Media that must be free from entrapped air and foreign particles
- ▶ High-viscosity base and raw materials

### Industrial version

- ▶ Coating and casting compounds
- ▶ UV, hydro and wood fillers
- ▶ PVC printing/insulating paints
- ▶ Lanolin (wool wax)
- ▶ Varnishes
- ▶ Locher paste for sealing with hemp

### Pharma Food Cosmetic version

- ▶ Tomato puree
- ▶ Paste-like condiments
- ▶ Fruit sauce
- ▶ Creams and ointments such as zinc oxide ointments
- ▶ Vaseline
- ▶ Hand cleaning pastes

### General advantages

- ▶ **Mobile use**  
Can be moved to the drum without a crane or fork-lift truck
- ▶ **Low space requirement**  
Can be transported even in lifts
- ▶ **One transfer system for different drum types**  
Also suitable for conical drums
- ▶ **One transfer system for many drum diameters**  
Individual designs available on request
- ▶ **Cost savings**  
Efficient use of the medium and low expenditure for disposal
- ▶ **High process reliability**  
due to hermetic sealing of the medium even if the transfer process is interrupted
- ▶ **Energy savings**  
Usually no heating of the medium necessary
- ▶ **No structural change to the medium**  
due to gentle transport
- ▶ **Easy cleaning**  
as the system can quickly be dismantled
- ▶ **Flexible application**  
due to flexible modular system of the individual components (pump, motor etc.)

### Special advantages of the Pharma Food Cosmetic version

- ▶ **Transfer out of conical drums even with aseptic bags**  
due to double lip variant
- ▶ **Aseptic bag needs not be fixed**  
due to constructional side effects
- ▶ **Resistant to aggressive cleaning agents**  
due to protecting stainless steel elements
- ▶ **Can be moved in explosion hazard zone 1**  
due to conductive stainless steel castors with sealed ball bearings

### Technical data

- ▶ Standard: Drum diameter 560 mm or 571 mm;  
Pharma Food Cosmetic version also for conical drums with diameters of 550 mm at the top and 515 mm at the bottom
- ▶ Height of overall system see page 5
- ▶ Compressed air supply to support lifting function needed



# VISCOFLUX mobile

Flexible, gentle and efficient



The VISCOFLUX mobile system can quickly and easily be transported to the selected drum. The pump unit with the self-priming eccentric worm-drive pump guarantees especially gentle transfer of the fluid. The hermetically sealed follower plate provides high process reliability, allowing interruptions of the transfer process. The double lip variant of the Pharma Food Cosmetic version is ideal for conical drums with aseptic bags.



VISCOFLUX mobile – stand-alone system - mobile without crane or fork-lift truck (example: industrial version).



VISCOFLUX mobile – easy handling, gentle transfer (example: Pharma Food Cosmetic version).



VISCOFLUX mobile – high process reliability even if the transfer process is interrupted.

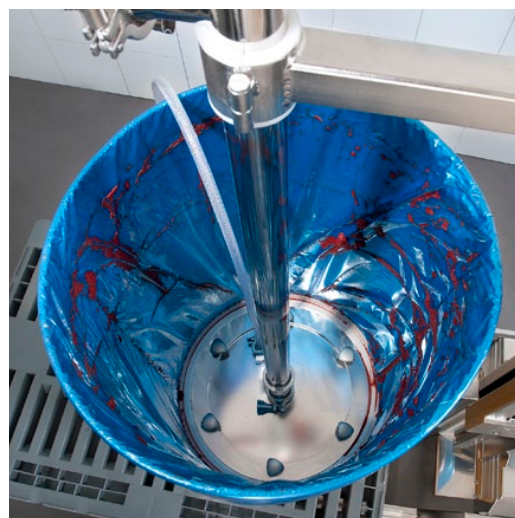

VISCOFLUX mobile – ideal for transfer out of conical drums with aseptic bags (example: Pharma Food Cosmetic version).

# VISCOFLUX mobile

Mobile use, easy to clean

Due to its mobile lifting device, the VISCOFLUX mobile can be transported quickly and easily to the drum or the cleaning place - even across floors. Its extremely compact design allows the transport of the system in a lift. After use, the pump unit consisting of motor, pump and follower plate can be dismantled quickly for cleaning.

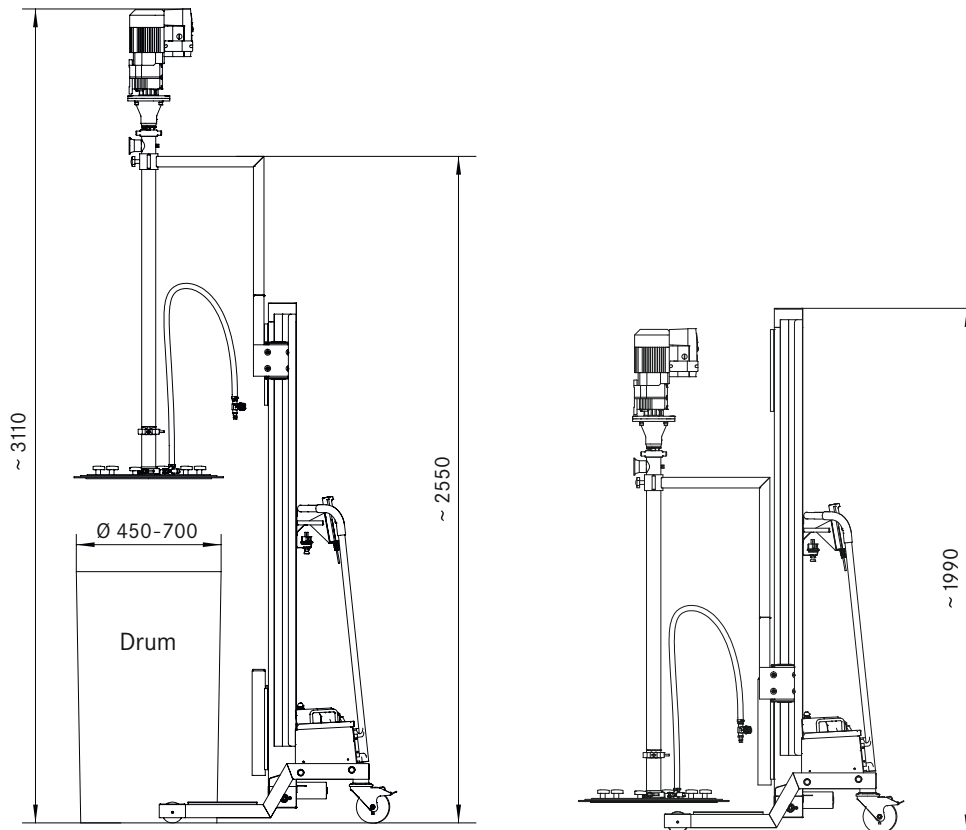

VISCOFLUX mobile - its size is an additional advantage over other systems!

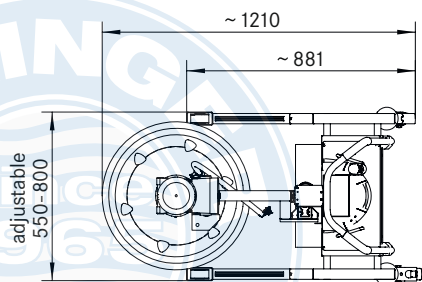

VISCOFLUX mobile - low space requirement due to compact design.



VISCOFLUX mobile - mobility across floors.



FLUX is a world renowned brand for the highest standards in pump technology. It all began in 1950 when the electric barrel pump was invented. Today, our wide range of products includes barrel and container pumps, centrifugal immersion pumps, excentric worm drive pumps and air-operated diaphragm pumps as well as mixers, flow meters and, of course, an extensive range of accessories.

Apart from the outstanding quality of our FLUX products, our customers appreciate our staff's excellent expertise and real customer orientation.

Put us to the test. We are looking forward to hearing from you.



ESP-VFm 03 12/2-E printed in Germany

FLUX-GERÄTE GMBH