

# XD 60™, XD 70™ and XD 80™ Motor Rewind Hose Reels



No Chains,  
Safer for  
Operators!



XD 70 >

XD 60 >



XD 80 >

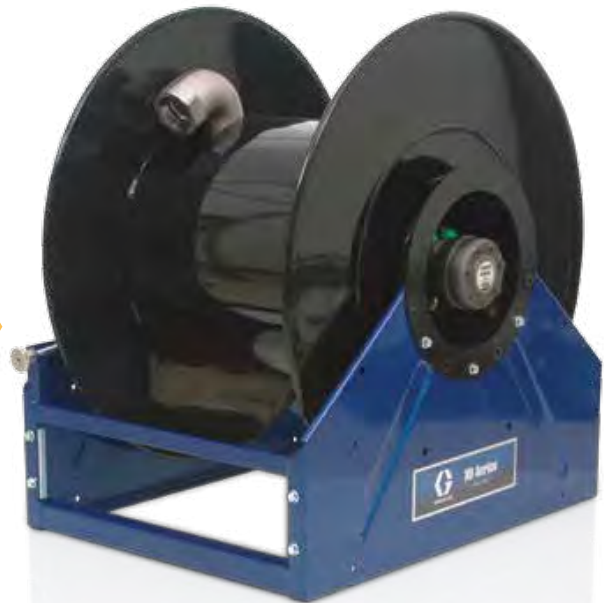

## Designed with Safety in Mind

Drive motors have no chains, no maintenance.  
No worries.

PROVEN QUALITY. LEADING TECHNOLOGY.

# Engineered for Safety

## Safe and Reliable Direct Drive Motor Design

XD Power Rewind motors are built to fit into the spool, protecting components from the elements and protecting users from pinch points that could cause injury. No chain to rust or break—nothing to lubricate, no maintenance.

## Incomparable Versatility with Modular Design

Choose from multiple frame and motor combinations—mix and match to make quick work of configuring the reel for your application. Reels can easily be configured for left or right hand connections by switching the outlet and motor rotation to suit your needs. Order reels assembled, or choose frames and motor modules to maximize uptime for on-site installations.



### *Robust Electric and Pneumatic Motors*

- Gear drive is enclosed and tucked into the spool to promote long life
- Nothing to lubricate for more efficient performance
- No exposed chains that can cause injury to the operator
- Easy change-out for less downtime in the field

### *Compact Hydraulic Motor*

- Significantly narrower footprint fits in tighter spaces
- True 1-to-1 ratio direct drive provides more efficient operation
- Motor is protected by the spool for longer life
- No chain to lubricate

## The Graco Advantage

### XD Series Motorized Reels

- More uptime due to less maintenance
- Eliminates the chains which are dangerous to the operator
- No need to purchase additional chain guards
- Lubed for life, no need to lubricate drive
- Cleaner installations
- Hydraulic 1:1 ratio motor is more efficient and provides easier retraction over chain drive designs
- Easily stock components for faster, in the field service
- Simple to configure for right or left hand inlet
- Outlet minimizes hose kinking for an even, smooth wrap

### Competitive Motorized Reels

- Chain drives require cleaning and maintenance that can add extra expense
- Chain drive can be dangerous to operators
- Chain guard protection adds to the reel cost
- Requires time for lubrication maintenance
- Greasy, rusty and dirty chains can break and cause inefficient operation and poor retraction
- Not modular—difficult to stock components

Industry leading  
**7 YEAR WARRANTY**  
1 Year on wear components

# Safe, Versatile and Super Powered.

We like to think of the XD Motor Rewind Reels as Super-Powered. The innovative design is packed with features to help you work safer, smarter and faster. We demand extensive product testing, often exceeding industry standards to ensure you get the best product on the market. Plus, it's all backed with an industry leading warranty and support after your purchase.

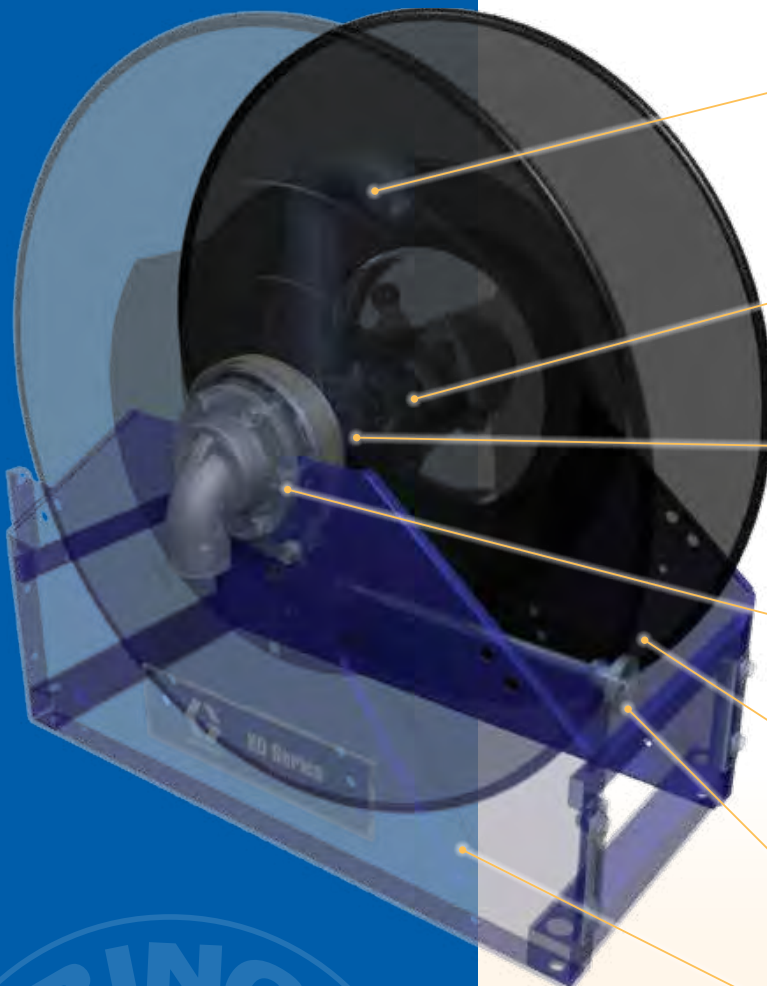

## **Easy Hose Installation**

The outlet can be removed easily for hassle-free hose installation. Designed to minimize hose kinking for a more even and smoother wrap. Nickel plated fluid section to prevent corrosion for longer life.

## **Safe, Reliable Direct Drive and Gear Motors**

Drive unit is clean and lubricated for life. No need to worry about greasy, exposed drive chains that need maintenance and can be dangerous to operators.

## **More Flow—Less Pressure Drop**

A Graco exclusive—breakthrough swivel design (patent pending) allows better flow to get work done faster. Materials are corrosion resistant and strong for long lasting performance.

## **Easy System Integration**

Easily change the inlet and motor direction to give you the option of a right or left hand flow orientation.

## **Heavy-duty Welded Spool**

Built to handle the weight of heavy hoses. Designed to surround and protect the drive unit from the elements to promote longer lasting, safer operation.

## **Easy Access Brake**

Band clamp brake used to slow and stop hose retraction is adjustable for your application.

## **Rugged and Durable Body**

Heavy-duty one piece welded frame is engineered to flex under extreme operating conditions and is stronger than bolted frames that can loosen with use. Individually painted and powder coated components have superior corrosion resistance over assembled and painted products.

Proudly built in the U.S.A.  
Sold and supported worldwide.

North America Customer Service 800-533-9655 Fax 800-533-9656

 [www.graco.com](http://www.graco.com)

Springer Pumps, LLC  
Telford, PA 18969

Tel: 866-777-6060 / Int'l: 215-949-2900  
Fax: 866-777-6383 / Int'l: 215-721-1296

[www.springerpumps.com](http://www.springerpumps.com)  
[info@springerpumps.com](mailto:info@springerpumps.com)



## XD Series Motorized Hose Reels

### Power for Larger Diameter and Longer Hose Lengths

- Direct drive motor options include hydraulic, pneumatic and electric 12, 24, 115, and 230 volt
- Available in 600 psi (41 bar) low pressure and 3,000 psi (207 bar) medium pressure models
- Operating temperature range of -40 to 180° F (-40 to 82° C)\*
- Adjustable band clamp brake used to slow and stop reel
- For Air, Water, Oil, Grease, Fuel Dispense, and Waste Oil Evacuation
- Optional roller guides and arms available as accessories

*Not all options available in every configuration. Please see ordering guide for available sizes.  
\* Grease reels are rated for 0° to 180° F (-18 to 82° C)*

### Frame Color Options

Choose from white, yellow or metallic blue for a professional look.

XD 60 >



<b>Hose Capacity</b>	Up to ½ in x 100 ft, ¾ in x 100 ft, 1 in x 50 ft
<b>Swivel Size</b>	1 inch npt inlet and outlet

XD 70 >



<b>Hose Capacity</b>	Up to 1 in x 100 ft, 1.5 in x 65 ft, 2 in x 33 ft
<b>Swivel Size</b>	1, 1.5 or 2 inch npt inlet and outlet

XD 80 >



<b>Hose Capacity</b>	Up to 1 in x 150 ft, 1.5 in x 100 ft, 2 in x 50 ft
<b>Swivel Size</b>	1, 1.5 or 2 inch npt inlet and outlet

## XD™ Series Reels

### Spend Less Time and Money on Service

Tested tough to perform when you need it. Constructed with quality materials for long lasting performance to help reduce downtime. Changing motors is easy so you get up and running fast.

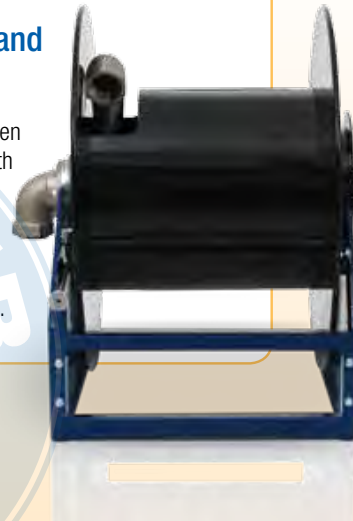

### Top Quality Solutions for:

- Mining Operations
- Oil and Gas
- Heavy-duty Construction
- Agriculture
- Sewer and Waste Water
- Transportation



## Why Buy Graco?

From bulk fluid pumping to precise dispense, Graco's got you covered

- Engineered features to help you work smarter and faster
- Choose the power and durability for your application—we offer a variety of products to fit your needs and budget
- Designed and tested with Graco quality standards and backed with outstanding worldwide sales and service
- Trusted field-proven durability for more than 85 years
- Category leading warranties
- Professional drawings and models available

## Compare Our Value

We provide competitive warranties on everything we make, plus Graco offers:

- A comprehensive warranty program including labor and travel
- Outstanding customer service

For complete details on product warranties visit [graco.com](http://graco.com) or check out the PMG Buyers Guide



North America Customer Service **800-533-9655** Fax **800-533-9656**



[www.graco.com](http://www.graco.com)

## AMERICAS

### MINNESOTA

Worldwide Headquarters  
Graco Inc.  
88-11th Avenue N.E.  
Minneapolis, MN 55413

### MAILING ADDRESS

P.O. Box 1441  
Minneapolis, MN 55440-1441  
Tel: 612-623-6000 Fax: 612-623-6777

## EUROPE

### BELGIUM

Graco BVBA  
Industrieterrein-Oude Bunders  
Slakweidestraat 31  
B-3630 Maasmechelen,  
Belgium  
Tel: 32 89 770 700 Fax: 32 89 770 777

## ASIA PACIFIC

### AUSTRALIA

Graco Australia Pty Ltd.  
Suite 17, 2 Enterprise Drive  
Bundoora, Victoria 3083  
Australia  
Tel: 61 3 9468 8500 Fax: 61 3 9468 8599

### CHINA

Graco Hong Kong Ltd.  
Shanghai Representative Office  
Building 7  
1029 Zhongshan Road South,  
Huangpu District  
Shanghai, 200011  
The People's Republic of China  
Tel: 86 21 649 50088 Fax: 86 21 649 50077

### INDIA

Graco Hong Kong Ltd.  
India Liaison Office  
Room 443, Augusta Point  
Regus Business Centre 53  
Golf Course Road  
Gurgaon, Haryana  
India 122001  
Tel: 91 124 435 4208 Fax: 91 124 435 4001

### JAPAN

Graco K.K.  
1-27-12 Hayabuchi  
Tsuzuki-ku  
Yokohama City, Japan 2240025  
Tel: 81 45 593 7300 Fax: 81 45 593 7301

### KOREA

Graco Korea Inc.  
Shinhan Bank Building  
4th Floor #1599  
Gwangyang-Dong, Dongan-Ku,  
Anyang-si, Korea 431-060  
Tel: 82 31 476 9400 Fax: 82 31 476 9801

©2013 Graco Inc. 341045 Rev. A 08/13 All other brand names or marks are used for identification purposes and are trademarks of their respective owners. All written and visual data contained in this document are based on the latest product information available at the time of publication. Graco reserves the right to make changes at any time without notice.

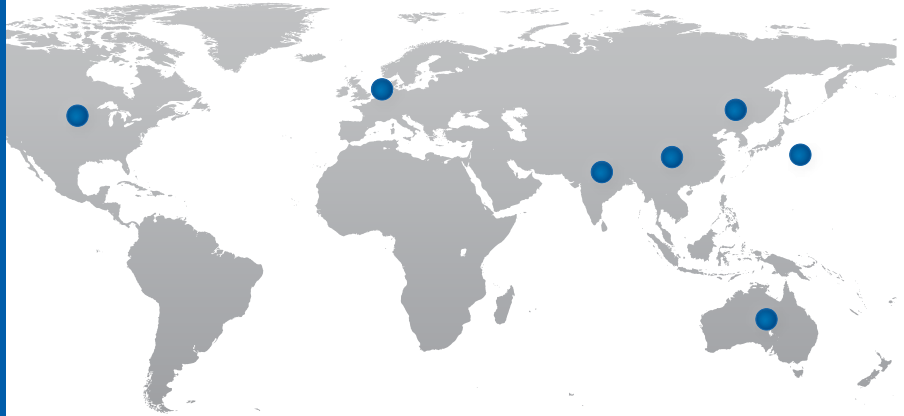

# Graco's got you covered

## Facilities Worldwide for Global Support



### Quality First

At Graco we pride ourselves on providing best-in-class products. Engineered solutions are manufactured in our own facilities, with the highest standards in the industry. We provide you with world-class customer support and expertise to help solve your lubrication challenges.



### Global Reach

Graco has facilities across the globe to provide you with the products and service *you* need, where *you* live. Plus, Graco has dedicated field experts in all areas of the world to support the products we sell.



### Product Capabilities

Graco has a broad range of products to provide solutions that meet your needs. Our products are engineered and tested to perform in the harshest environments so you can be certain your equipment is protected and working at peak performance.

