



SP/40 CIP High Performance Clean-In-Place Hosepumps

Features and Benefits

- Cam actuated retractable shoes allowing true Clean-In-Place (CIP) operation for sanitary processes
- Electric, pneumatic, or manual actuator allowed automated CIP operation
- NBR/Buna N and Bioprene hoses are manufactured in conformity with the FDA's regulations and stainless steel sanitary connectors are available for food industry applications. Natural Rubber, EPDM, or Hypalon hoses for other industries.
- Can run dry continuously
- Most suitable for handling shear sensitive products
- Accurate (+1%) dosing (metering) capabilities
- Smooth liquid passage without valves, dead corners, or glands
- The material to be pumped does not contact mechanical parts of seals
- Easy maintenance, low cost, short down time
- Only one wearing part: the hose
- Easily and completely cleanable
- Easily adjustable and reversible rotation
- Suitable for high viscosity and densities
- No metal contact or valves
- Safe for use in explosive environments
- No internal back flow (slip)
- Designed to pump liquids containing particles (abrasion is no restriction)
- Self priming to 95% vacuum
- One year comprehensive warranty

Performance Chart

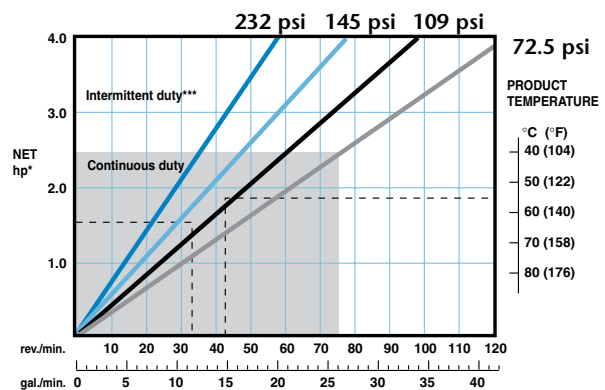

How to calculate speed/horsepower

- Flow required, indicates pump speed
- Calculated discharge pressure
- Horsepower required
- Fluid temperature
- Calculated discharge pressure
- Maximum recommended pump speed**

* Minimum starting torque 2,835 in lbs. based on starting unloaded at atmospheric discharge pressure. Starting torque can be 2-3X running torque if starting under the load of higher discharge pressures. ** For maximum hose life, speed point (A) should be lower than temperature adjusted speed point (F). See example points (A) thru (F). *** Intermittent duty = 2 hrs max continuous running, 1 hr stop before restart.

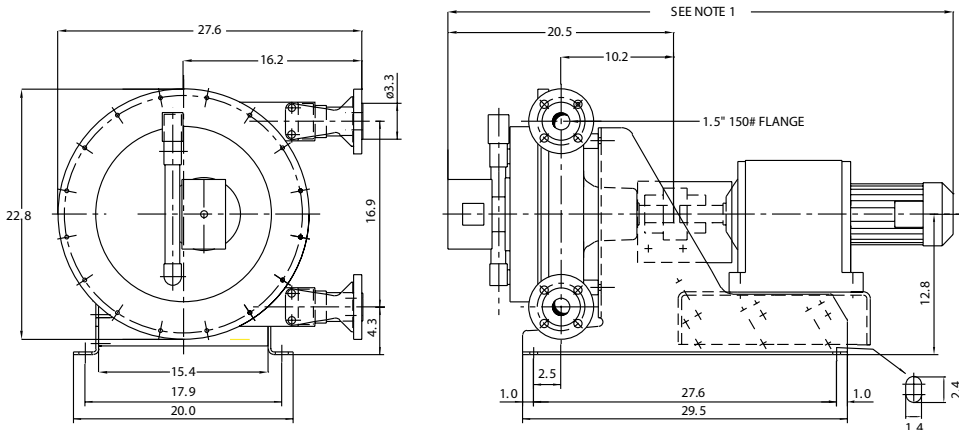

NOTE 1: LENGTH WILL VARY DEPENDING ON GEARMOTOR USED
ALL DIMENSIONS IN INCHES AND FOR REFERENCE ONLY
PUMP SHOWN IN POSITION 2 WITH 2\"/>

Dimensions

A	412	P (st. steel)	83
A1	702	P (PVC, PP)	80
Amax	446	P (PVDF)	70
Amin	401	S	140
B	430	T	412
B1	110	T1	360
B2	615	T2	392
C	580	T3max	140
D	174	T4	91
E1	428	V	325
F	86	X	750
F1	64	X1	700
G	340	Y	25
G1	454	Y2	61
G2	508	Z1	18
H	M12	Z2	30
Hmax	201	Od	40k6
Hmin	123	e (manual operation)	441
K	40	e (air operation)	537
L	110	e (electric operation)	674
M	150	I	80
n x N	4x18	u	12
O (st. steel)	2.5	t	43
O (PVC, PP, PVDF)	10		

The information contained in this document is believed to be correct, but Watson-Marlow Bredel Pumps accepts no liability for any errors it contains, and reserves the right to alter specifications without notice.

SP/40 CIP Clean-In-Place Hosepumps

Technical Specifications

- Displacement:** 0.351 gal/rev
 - Supply:** 115/230VAC 1-phase or 230/460 or 575 VAC 3-phase
 - Operating Speeds:** Up to 75 rpm continuous
Up to 110 rpm intermittent
 - Fluid Temperature Range*:** 14°F to 176°F
 - Ambient Temperature Range**:** -4°F to 113°F
 - CIP Mode:**
 - Max initiation speed: 60 rpm
 - Max CIP fluid temperature: 248F
 - Actuators: Manual, Pneumatic, Electric
 - Hose Lubricant Volume:** 1.3 gallon
 - Flow Range:** Up to 39 GPM
 - Discharge Pressure:** Up to 232 psi
 - Suction Pressure:** 28 ft. lift to 45 psi
 - Hose Materials:** BUNA N, Natural Rubber, EPDM, Hypalon, Bioprene***
 - Fittings:** 1.5" 150# flange or 316SS 1.5" tri clamp style
 - Flange Insert Materials:** 316SS, Polypropylene, PVC, PVDF
 - Optional High Level Hose Leak Sensor:** NO or NC: 1A max, 250V max, 50 V A max
- When installing, allow min 44" linear clearance from ports to facilitate hose changing

Materials of Construction

- Pumphead:** Cast Iron
- Rotor:** Cast Iron
- Shoes:** Aluminum or Epoxy
- Shims:** Galvanized Steel or 304SS
- Cover:** Mild steel
- Flange Brackets:** 304SS
- Base and Supports:** Galvanized steel or 304SS
- Hardware:** Zinc plated steel or 316SS
- Hose Clamps:** Steel, 304SS or 316SS
- Shaft:** Alloy Steel
- Seals:** Buna
- Coupling Guard:** 304SS

*Consult Watson-Marlow Bredel for lower or higher temperature operation

**Allowable ambient temperature is based on pump capabilities and may be further limited by gearmotor ambient capabilities.

***Please contact Watson-Marlow Bredel Pumps Application Engineering for sizing.

The information contained in this document is believed to be correct, but Watson-Marlow/Bredel Pumps accepts no liability for any errors it contains, and reserves the right to alter specifications without notice.

Springer Pumps, LLC

861 Tech Drive • Telford, PA 18969
Tel: 866-777-6060 • Fax: 866-777-6383
info@springerpumps.com • SPRINGERPUMPS.COM